

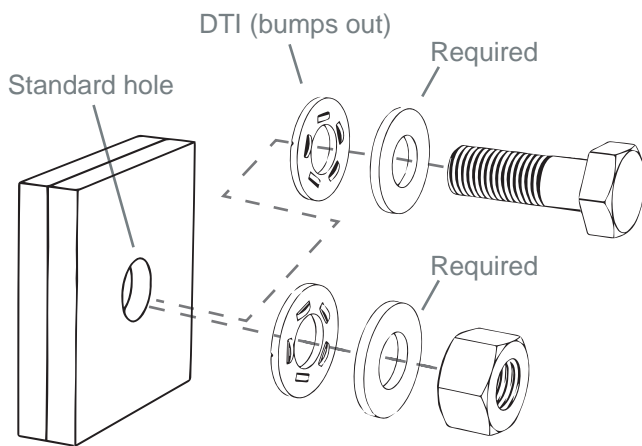

Verification

Step 1



Assemble hardware in the steelwork.

Step 2

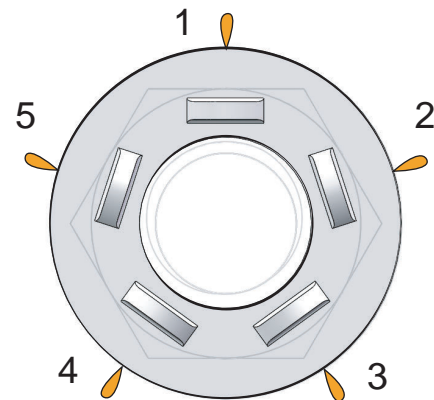

Tighten until the DuraSquirt® DTI has orange visible at all bump locations.

Step 3

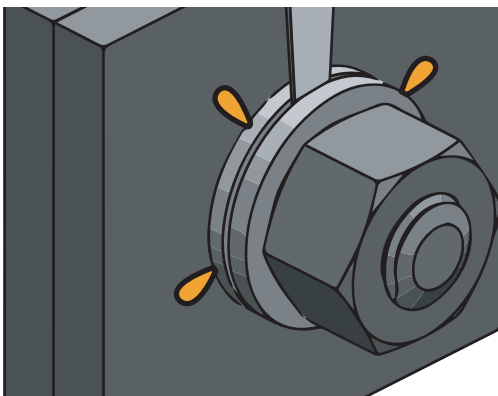

Confirm the gap is smaller than the calibrated gap provided by Applied Bolting Technology.

Completely flat is acceptable after orange fully emits at bump locations.

The visual inspection method is now confirmed for use in the steelwork.

DuraSquirt® DTI Installation and Inspection

Assemble

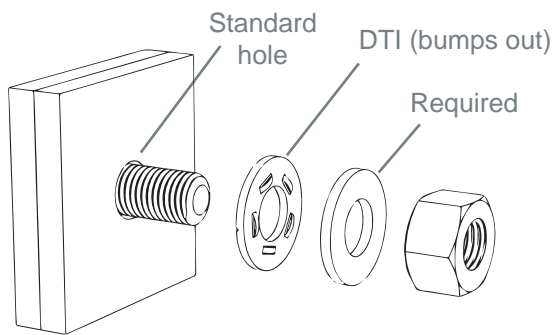

Recommended

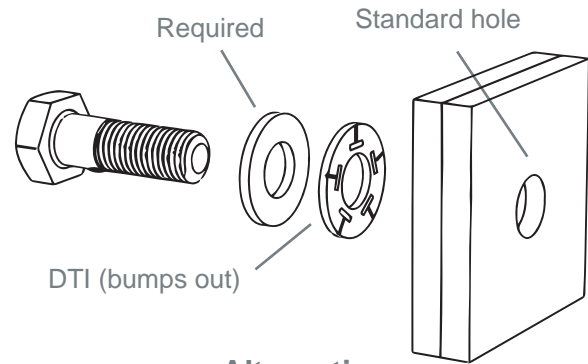

Alternative

Snug

Bring the steelwork together before orange is visible at all bump locations.

Tighten

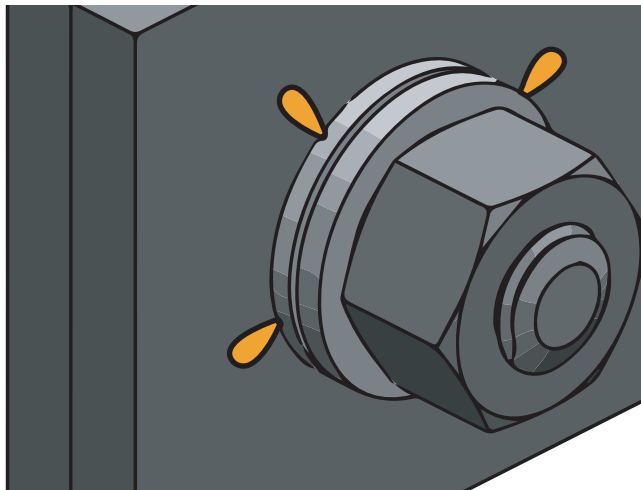

Tighten until the DuraSquirt® DTI has orange visible at all bump locations.

Inspect

Verify Durasquirt® DTI has orange visible at all bump locations.

If it's not easy call us! We want you hanging iron.

(802) 460-3100 or **appliedbolting.com**

Check the website for bolting resources; Including test forms.

Videos, and Tips



Scan for support